

KNOWLEDGE MANAGEMENT IN THE PAKISTANI BANKING SECTOR: A COMPREHENSIVE ANALYSIS

Sarah Fatima

Hailey College of Commerce, University of Punjab, Pakistan.

DOI: <https://doi.org/10.5281/zenodo.14236790>

Abstract: Knowledge is an invaluable asset, and its proper management and utilization are key to progress in today's dynamic world. The evolution of human economies from agricultural to industrial has highlighted the significance of knowledge as a pivotal factor. While land and labor were traditionally essential, it became increasingly evident that knowledge, residing within the human mind, holds equal importance. This shift in perspective has reshaped our understanding of economic development, emphasizing the critical role of knowledge as a driving force in contemporary societies.

Keywords: Knowledge, Economy, Industrialization, Human Development, Economic Progress

1. Introduction

Knowledge is something which has only intrinsic value and its extrinsic value only lies in properly managing and utilizing it. Human being was first living in a agricultural economy and after the breakthrough of technology , human first enter into industrial economy and land and labor was the two factors of prime importance in that economy. But as time passed it was found that only land and labor are not enough another important thing to be considered is the knowledge that resides in the mind of human being.

Today we have move towards the knowledge based economy from industrial economy “The basic economic resource is no longer capital, nor natural resources, nor labor. It is and will be knowledge” (Peter Drucker). Knowledge can be defined as “Set of skills, capabilities, information and experience that are used by the individuals to solve different problems is known as Knowledge” (Baker et al. 1997). “The way an organization create, use, share and store knowledge in known as knowledge management” (Probst et al. 1998).

In today’s world people are widely admitting this fact that in order to have best utilization of any other resources of an organization, the essential role of knowledge resource cannot be overlooked. And in this era of extensive competition, such competitive edge is required which could be rarely copied and distinguish the organization from rest of the organizations. This edge is surely be achieved by managing the knowledge of its valuable people. As Prime resource of any organization is not its financial resource or technical resources but it is the knowledge which is enclosed in the mind of its human, Malhotra (1997). Knowledge base resources are the path or way that we have to follow in order to have a sustainable competitive edge otherwise we will be out of the game.

Current economic crisis of Pakistan require that organizations value its assets/resources only then organizations can achieve an edge and can grow. And among all other sectors the prime sector is financial sector where

management of knowledge is as crucial as blood for life. That's why focus of this article is on banking sector of Pakistan. This article is mainly putting emphasis on the discovery of those crucial elements which have a powerful impact on management of knowledge within the organization. So factors of concern in this article are leadership, culture and information technology.

2. Literature Review

In 1990 the concept of knowledge management was given proper attention and the “knowledge Management Foundations: Thinking about Thinking – How People and Organizations Create, Represent and use Knowledge” was introduced and published by Karl Wiig (1993).

Knowledge management can be defined as adopting such approach which is systematic so that knowledge assets of an organization can be best managed (Dunn and Neumunster (2002). Then this definition was made more simple and concise by Novins (2002). He said that knowledge management is that process in which right information is stored, and then right people received this and used rightly by those people.

Then KM is subdivided into two very important parts. First that knowledge which is in form of code (numbers/symbols etc) and communicated in this form. Second is that knowledge which comes thorough experience and expressed as actions of a person such as his motivation, his views, his behavior, his commitment etc. The difference between two lies in explicit knowledge is related to “why thing work” and tactic is related to “what things work”. Knowledge management is heavily dependent on the factors such as leadership, culture and information technology.

2.1 Leadership

Leadership is proved by many researchers of KM to be the key antecedent of the knowledge management which leads to the effectiveness of the organization (e.g. Bell De Tienne, 2004). In today's world globalization has invalid the statement made in 1980s and 1990s, that only one leader is enough to manage the knowledge. And in oppose of this, there is a belief today that at all hierarchical level of the organization, knowledge management leader must be there.

In order to further elaborate this belief Debowski (2006) said that in order to motivate the knowledgeable people, to build communication channels, guide others to share knowledge and to make efforts to make the process effective is the prime role play by the knowledge management leader. He also said that leaders are the only people elaborate the basic goal of managing the knowledge to the knowledgeable employees and to guide them towards the right path in achieving those goals.

As it has proved through research that success of the organization is not only dependent on giving the fringe benefits to employees or through developing a very strong culture but also heavily dependent on the effective leaders, Stewart (1997).

There is no doubt in this that only leaders have influence on the people/employees and knowledge is something which is directly link with people so leaders are the only source through which organization can approach and achieve the goal of knowledge management. (DeTienneet al., 2004).

Cleveland (1985) emphasis that it's the core job of leaders to develop different kinds of networks such as groups and communities in order to have an effective knowledge management.

2.2 Culture

People use their vales, believes, assumptions, norms as a guide that help them to perform their daily activities. Every organization's culture is distinctive, and it influence the way people perform. Because culture lies in

values, beliefs, and, norms that people follow. (Hofstede, 1980). According to De Long and Fahey (2000), culture play a very important role in knowledge creation, sharing, and use in several ways. Culture should be such that provide: flexibility, social interaction, trust etc. The culture of project has effect on the intelligence and values of individual that's why it is called a powerful integrator (Brătianu, Jianu, Vasilache, 2007).

According to (Miller, 1995, p. 121) organization culture changes over time, because due to increase competition and rapid changes in the external environment, organizations have to adopt the change and change their culture accordingly.

Further Miller said that organization culture is evolving and complex in nature. Organizational culture explains how people cooperate with each other and works together; it also explains the category of people who fit into the organization. And most importantly for successful Knowledge management initiatives, culture plays an important role (Gupta and Govindarajan, 2000; Gummer, 1998).

Today, researches related to Knowledge management are mainly focus on Culture of the organization, because culture play a very important role in promoting knowledge management and several studies shows that people interact with each other in their work environment (Blackler, 2000).

Organization work environment is a place where organization culture prevails and people communicate and perform their work accordingly (Gupta and Govindarajan; 2000). Coordination among team members is very important for the success of KM initiatives because in this way they communicate with each other and share their knowledge and experience. (Nonaka and Takeuchi, 1995).

According to researcher's viewpoint, an encouraging, helpful, cooperative culture is fundamental for success of knowledge management initiatives in an organization e.g. Lopez et al., 2004; Kulkarni, Ravindran & Freeze, 2007). Wallach (1983) gives three types of organizational culture:

2.2.1 Bureaucratic Culture - in this type of culture rules and regulations are strictly follows, work is done systematically.

2.2.2 Innovative Culture - this type of culture is involved in risk taking, imagination, developing something new.

2.2.3 Supportive Culture - The culture of being caring and helpful for others, provide support in difficulties, encourage others.

Trust is a prerequisite for successful KM initiatives. Without trust people will be cynical about the intentions and behavior of others and they hold back their knowledge. So the need is to build a trustworthy culture in organization and a strong relationship should be build between organizations, its employees, and its sub-units. This will help in a more Hands-on and open knowledge sharing process between individual .Then this knowledge will be saved in a database for future use. (De Long, Fahey, 2000).

2.3 Information Technology (System)

Information technology is the way to achieve a well administered approach towards the knowledge management. As compare to past, in the present days IT advances are making it easier to acquire, store and spread knowledge. Success of Knowledge management process is based on the proper utilization of information technology (Dougherty, 1999).

A very significant role in knowledge management is played by knowledge management system as without it its very hard to have a value added Knowledge Management. Knowledge Management Systems (KMS) are used in the creation as well as its storage and sharing among the people. (Duke et al., 1999; Bonner, 2000).

A sustainable competitive advantage can surely be achieved through management of knowledge so this fact has led many firms to adopt KMSs which are source knowledge sharing as well as integration of knowledge (Bolloju et al., 2002)

Codification and personalization are two main ingredients provided by it to support KM (Hansen et al. 1999). Explicit knowledge is stored in codes in data bases and other people can use the same knowledge to save resources which is possible through IT. Tacit knowledge is shared personally but with the help of IT people can be searched and then knowledge is shared such as video conferencing etc

3. Purpose of Research Study

There is frequent saying in banking industry that “all our stakeholders are important” but our clients are on the priority. Clients can only be pleased when they got their preferred services. This is only achievable when employees have sufficient knowledge about what kind of services their bank provided as well as their competitors. They can serve their customers more exuberantly when they exploit knowledge management system. Many banks have now invested in designing and implementing knowledge management centers (KMC) but few banks still ignore this area. This hypothesis needs to be vigilantly tested. This research study addresses this assumption directly and therefore the focus of the research borders around which factor of knowledge management makes any difference in the performance of bank or not.

4. Research Design

Convenience sampling technique (a form of non-probability sampling) was used to collect data, a quicker way to get a huge number of completed questionnaires more swiftly and efficiently from the banks. All operating schedule banks listed on state bank of Pakistan’s website were selected for this study and their contact numbers and addresses were taken from their relevant websites and questionnaires were distributed by visiting the banks personally for primary data collection. The questionnaire consisting both open ended and close ended questions was designed on a five point-Likert scale having options 1 to 5 in which 1 for strongly disagree, 2 for disagree, 3 for neutral, 4 for agree and 5 for strongly agree. As the focus of the study is primarily on relationship between different levels in the banks so sampling units were all individuals (employees, leaders) working in selected banks. 275 questionnaires were distributed out of which 215 questionnaires received back and 200 were used for data analysis which shows 72% of total population. All the respondents were appealed to answer all the questions to the best of their knowledge. After data collection we coded it in SPSS version 20 and statistical tools like stepwise regression analysis, correlation and descriptive analysis were used to strengthen the results with numerical evidences.

4.1 Description of the Instrument

The questionnaire included gender, age, marital status, years of education of employees, position held by particular employee, experience with this bank and this industry and knowledge management practices. Out of all these items, only knowledge management practices were used for analysis. Factors for knowledge management include leadership, culture and information technology.

4.2 Variables

In this research study, leadership, culture and system (information technology) are considered as a factors in designing and maintaining knowledge management system in the banks operating in Pakistan.

5. Research Model

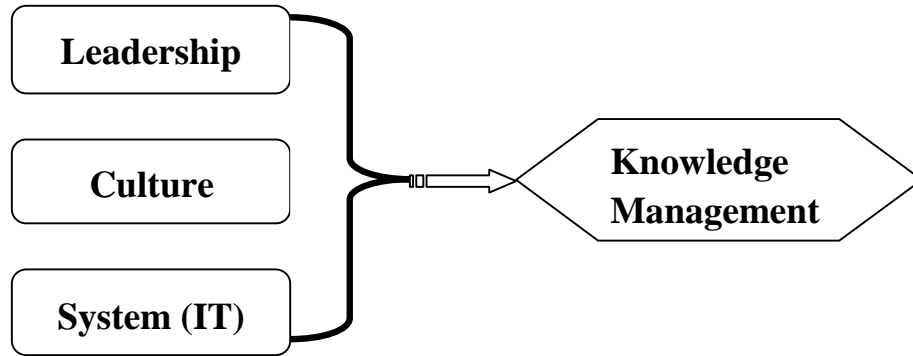

Hypothesis

H₁: Leaders, system and culture are the key factors in managing knowledge in banking sector of Pakistan

6. Research Findings

7.1 Analysis of Data

Data collection and analysis is the backbone of any research. After collecting data different test are performed in order to reach at significant findings.

7.2 Profile of Respondents

In this research 88.5 % male & 11.5 % females have participated out of total selected sample. According to the statistics respondents between 20-30 years are 57.5 % and above 30 are 42.5%. In conducted research 42% responses have taken from married and remaining 58% are from singles. Most of data is collected from private banks (80%) and ratio of non-mangers is 80% as compare to managers 20%. Most of them are working in organization for about 2-5 years (46%).

Table 1: Relationship between leadership, Culture and Information Technology

Leadership		T	p	Leadership Average	Culture Average
Gender	Male	2.186	0.037		
	Female				
Age	20-30	-0.994	0.322		
	30 or above				
Marital Status	Married	0.193	0.847		
	Single				
Education	Graduate	-0.758	0.449		
	Post Graduate				
Sector	Public	-3.528	0.001		
	Private				
Position	Manager	1.637	0.107		
	Non-Manager				
Leadership Average					
Culture Average				.662(**)	
				.000	
System (IT) Average				.634(**)	.675(*)
				.000	.000

Powerful relationship is found between culture, leadership and IT. It shows that these variables have effect on each other. If any fluctuation (upward or downward) takes place in the values of one variable, values of second variable also fluctuate in the same direction.

Table 2: Relationship between Leadership and Demographic Variables

In order to have an analysis of how different demographic variables are related to the leadership independent sample t test was conducted to compare leadership score of different demographic variables.

The significant equal variance not assumed two tailed is below the cutoff point of .05 for gender, age, sector, education and sector so we conclude that there is statistically significant difference in the mean of leadership scores for male and female, for public and private sectors, for graduate and post graduate and for different age groups of employees.

While significant is above the .05 for marital status this is the indicator that difference between mean score of single and married is insignificant.

Table 3: Relationship between Culture and Demographic Variables

Culture		T	p
Gender	Male	1.348	0.189
	Female		
Age	20-30	-1.475	0.142
	30 or above		
Marital Status	Married	182.323	0.645
	Single		
Education	Graduate	-1.812	0.072
	Post Graduate		
Sector	Public	-3.789	0.000
	Private		
Position	Manager	1.275	0.208
	Non-Manager		

Now to make comparison of mean scores of demographic variables for culture another independent sample t test was used. For single and married employees it was found that they rate culture in the same way as their significant is more than .05.

The significance is less than .05 for gender, age, sector, education and position so we conclude that there is significant difference in the mean of culture scores for male and female for public and private sectors for graduate and post graduate and for different age groups of employees.

Table 4: Relationship between Information Technology and Demographic Variables

Information Technology (System)		T	p
Gender	Male	-0.171	0.865
	Female		
Age	20-30	-2.095	0.038
	30 or above		
Marital Status	Married	164.673	0.860
	Single		
Education	Graduate	-1.672	0.096
	Post Graduate		
Sector	Public	-4.831	0.000
	Private		
Position	Manager	1.966	.054
	Non-Manager		

Comparing mean scores of demographic variables for information technology results indicate that the significant level for equal variance not assumed is below the .05 for, age, sector, education and position so we conclude that difference is significant for the mean score of public and private sectors for graduate and post graduate and for different age groups of employees.

And no difference is found in mean scores of single and married and male and female as significance level is above .05.

Table 5: Anova

ANOVA			
		F	P
Leadership	1-5 years	3.175	0.015
	5-10 years		
	10-15 years		
	15-20 years		
Culture	1-5 years	0.957	0.432
	5-10 years		
	10-15 years		
	15-20 years		
Information Technology	1-5 years	2.019	0.093
	5-10 years		
	10-15 years		
	15-20 years		

7. Conclusion

The rationale behind conducting this research is to have in-depth analysis of the sound factors of Knowledge Management. And after adopting a well administered approach of collecting data we reach at valuable results and concluded that Banking sector is like a house of knowledge where no one feel hesitation in sharing their knowledge with their co-workers.

It is found that Leaders in banks are the main stream to support knowledge flow in and between organizations. Also very prominent source of knowledge sharing is Culture which represents that people have attitude of sharing not hiding and behavior of individuals is supportive in organization .Also its pertinent to note that in this competitive world banks in Pakistan are using a well-functioning technological system which support effective Knowledge management.

So presence of all these factors ensures the success of any banking sector. As they realize the fact that real asset of any organization is knowledge of its people .And by adopting knowledge as competitive advantage success can't be hinder.

Followings are some boundaries of the study conducted:

Firstly the focus of study is only to explore the presence or absence of factors of Knowledge Management and not to see effects of these on organization performance. Secondly the target of study is only banking sector and all other sectors remain unexplored and also limited resource availability bounds the sample collection to few geographic areas. So if these limitations are removed then more reliable conclusions can be drawn.

Recommendations

It's the requirement of time that companies should adopt a sustainable competitive edge and for this purpose they should focus on their knowledge assets. Companies should view this research as a source of exploring the factors of knowledge management. And this research should be carried out further to know the effects of these on performance of different sectors of Pakistan.

References

- Bell De Tienne, K., Dyer, G., Hoopes, C. and Harris, S. (2004). Toward a model of effective knowledge management and directions for future research: culture, leadership, and CKOs. *Journal of Leadership and Organizational Studies*, 10(4), 26-43.
- Bonner, D. (2000). *Leading Knowledge Management and Learning*, American Society of Training & Development, Alexandria: VA,
- Bolloju, N., Khalifa, M. and Turban, E. (2002). Integrating knowledge management into enterprise environments for the next generation decision support. *Decision Support Systems*, 33(2), 163-76.
- Blackler, F. (2000). Collective Wisdom. *People Management*, 6(13), 61-63.
- Bratianu, C., Jianu, I. & Vasilache, S. (2007). An integrative perspective on the organizational intellectual capital in international conference on Business Excellence, Brasov: Romania
- Baker, M., Baker, M., Thorne, J. and Dutnell, M. (1997). Leveraging human capital. *Journal of Knowledge Management*, 1(1), 63-74.
- Cleveland, H. (1985). *The Knowledge Executive*, E.P. Dutton, New York: NY.
- Duke, S., Makey, P. and Kiras, N. (1999). *Knowledge Management 1999 Report Series*, 1: Butler Group Hull,

- Dunn, J. and Neumeister, A., (2002). Knowledge Management in the Information Age. *E-Business Review* Fall, 37-45.
- Gupta, A.K. and Govindarajan, V. (2000). Knowledge Management's Social Dimension Lessons from Nucor Steel. *Sloan Management Review*, 42(1), 71-81.
- Gummer, B. (1998). Social Relations in an Organizational Context: Social Capital, Real Work, and Structural Holes. *Administration in Social Work*, 22(3), 87-105.
- Kulkarni, U.R., Ravindran, S., & Freeze, R. (2007). A knowledge management success model: Theoretical development and empirical validation. *Journal of Management Information Systems*, 23(3), 309-347.
- Lopez, S.P., Peon, J.M.M., Ordas, C.J.V. (2004). Managing knowledge: the link between culture and organizational learning. *Journal of Knowledge Management*, 8(6), 93-104.
- Malhotra, Y. (1997). Knowledge management in inquiring organizations. *Proceedings of 3rd Americas Conference on Information Systems (Philosophy of Information Systems Mini-track)*, Indianapolis, 15(17), 293-5.
- Miller, K. (1995). *Organizational Communication: Approaches and Processes*. Belmont, California: Wadsworth Publishing Company.
- Nonaka, I. and Takeuchi, H. (1995). *The Knowledge-Creating Company: How Japanese Companies Create the Dynamics of Innovation?* New York, New York: Oxford University Press.
- Novins, P. (2002). Knowledge Management for Competitive Advantage and Shareholder Value. *E Business Review*, Fall2002, 33-36.
- Probst, G., Bu'chel, B. and Raub, S. (1998). Knowledge as strategic resource. In Krogh, G., Ross, J. and Kleine, D. (Eds), *Knowing in Firms. Understanding, Managing and Measuring Knowledge* (pp. 240-52). London/New Delhi: Sage.
- Vicky Dougherty, (1999). Knowledge is about people, not databases. *Industrial and Commercial Training*, 31(7), 262 – 266.
- Wallach, E. J. (1983). Individuals and organizations: The cultural match. *Training and Development Journal*.
- Wiig, Karl M. (1993). *Knowledge Management Foundations: Thinking about thinking how people and organizations create, represent, and use knowledge*. Arlington, TX: Schema Press.